

# OPERATING INSTRUCTIONS

## FORCE TRANSDUCER

### F30 Type 372 and F10 Type 375



**NOT FOR HUMAN USE**

## OPERATING INSTRUCTION

for the

### HSE Force Transducer F30 and F10

Type 372 and 375

(H.Steiert, Print date: September 20, 2013)

This transducer is manufactured under license from DLR (Deutsche Forschungsanstalt für Luft- und Raumfahrt e.V.), 5000 Cologne 90, Germany, by:

**HUGO SACHS ELEKTRONIK - HARVARD APPARATUS GmbH,  
Gruenstrasse 1, D-79232 March-Hugstetten, Germany**

Phone: (int +49) (0)7665-9200-0, Fax: (int +49) (0)7665-9200-90, e-mail: sales@hugo-sachs.de

<b>Contents:</b>	<b>Page</b>
1 General description, applications .....	2
1.1 Accessories, list of items .....	2
1.2 Unpacking, avoiding damage .....	2
1.3 Storage .....	3
1.4 Return shipment, packing .....	3
2 Operation .....	3
3 Notes on mounting in position .....	5
4 Overload and overload protection .....	6
5 Electrical connection .....	6
6 Calibration .....	7
7 Reduction lever (Microscale) UL5 .....	8
8 Natural frequency and damping .....	9
9 Servicing and maintenance .....	9
10 CE Declaration of Conformity .....	10
11 Technical data of the F30 force transducer .....	10
12 Bridge amplifiers suitable for F30 .....	11

## 1 General description, applications

The HSE force transducers F30 and F10 are designed for measuring small tensile and compressive forces and have a wide range of application. The range of the F30 is 0.3 N = 30 cN (approx. 30 g). The range of the F10 with 0.1 N = 10 cN (approx. 10g) is smaller by a factor of 3 and therefore particularly suitable for measuring extremely low forces. The displacement for the full working range of the F30 is 0.03 mm = 30  $\mu$ m. The F10 requires twice the displacement (0.06 mm = 60  $\mu$ m). Both transducers can therefore be considered as highly isometric units. Both the F30 and the F10 are ideally suitable for experiments on small muscle preparations, in particular the papillary muscle, since they are capable of reliably measuring very small forces. The transducers are not only suitable for measuring forces in muscle contractions but can also be employed for weighing tissues or in evaluating hand tremors.

The characteristic of the F30 is sufficiently linear up to about 80 cN. The noise is of the order of 0.002 cN (2 mg). The corresponding values for the F10 are 20 cN and 0.0005 cN (0.5 mg). This means that very small forces can still be measured. The natural frequency of the measuring system is near 440 Hz on the F30 (180 Hz on the F10) and is therefore sufficiently high for evaluating rapid contractions without error.

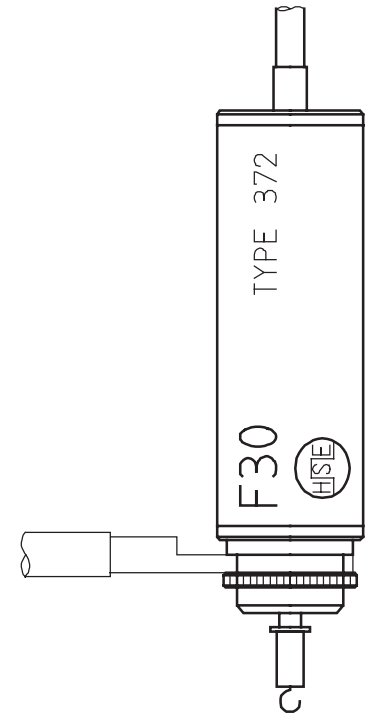

Fig 1: F30

### 1.1 Accessories, list of items

The transducer F30 and F10 are supplied in a plastic transport case. The standard accessories are included in the case and consist of:

- mounting nut (knurled nut, thread: M 16x1)
- mounting flange with mounting rod (8 mm dia., 155 mm long)
- push-on hook
- calibration weight with hook (1 cN = 10 mN)
- Operating Instructions for the F30 and F10
- calibration sheet

**Accessory:** reduction lever UL5 (option)

By using the optional reduction lever UL5 the sensitivity can be increased by a factor of 2, 5 or 10. When using the lever the displacement in the reduced ranges is increased proportionally. The speed of response (natural frequency of the system) is greatly reduced.

### 1.2 Unpacking, avoiding damage

Place the case in the correct position before opening it (narrow part of the case at the top)!

The sensing pin of the transducer is the most sensitive element. When you open the case, ensure that no uncontrolled forces can act on the pin. The transducers are effectively protected against overloads which might occur in normal use; but if a transducer is dropped, the measuring system may be damaged or even completely destroyed.

Check the contents of the case against the list above. If you cannot find the load hook or the calibration weight, look for it among the cushions. These small parts may become displaced during transport.

### 1.3 Storage

If the transducer is not in use it should be stored in its transport case for protection against damage. Never place it unprotected in a drawer together with other items; this is very likely to cause damage.

### 1.4 Return shipment, packing

If there is any need to return the transducer it is essential to use the transport case. Ensure that the sensing pin of the transducer is free and cannot come into contact with any other items during transport.

## 2 Operation

The operation of the F30 and F10 is based on the magneto-resistive principle in which a magnetically sensitive semiconductor resistance made from indium antimonide (InSb) moves in the field of a permanent magnet (field plate principle). The field plate takes the form of a meander-shaped resistance, similar to an etched strain gauge. The field plate is located in the field of a permanent magnet. Changes in the field line density alter the resistance of the field plate.

Fig. 2 illustrates the operation of the transducer. Four field plates (FP1 to FP4) are located inside the magnetic field of a U-shaped permanent magnet as shown. The core (A) is mounted on a spring-supported carrier; any displacement causes the magnetic flux to be shifted in the direction of the double arrow. This results in a change in the magnetic flux through the field plates and therefore in a change in resistance.

The field plates are connected electrically into a Wheatstone bridge circuit as shown in Fig. 3. The measuring system is adjusted so that the bridge is zeroed in the rest position. When the rod is loaded by a force (F) in the axial direction the core (A) is displaced by a distance (D). There is a corresponding change in the magnetic field acting at the field plates and therefore in their resistance, so that the bridge is unbalanced. This out-of-balance of the bridge can be measured as a corresponding bridge output voltage  $U_o$ .

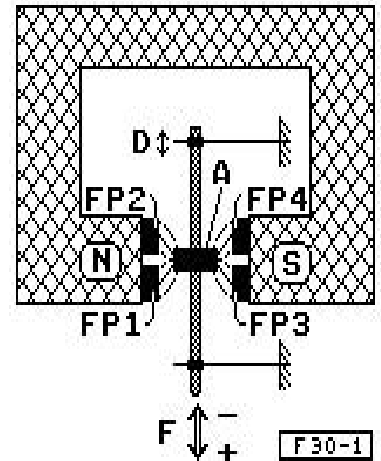

**Fig. 2:** Schematic diagram of F30

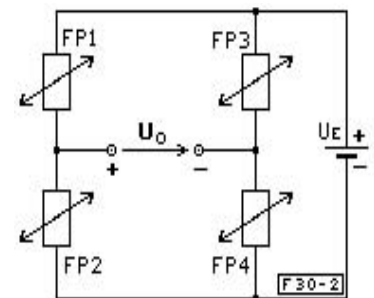

**Fig. 3:** Wheatstone bridge circuit of the field plates

In Fig. 4 the output voltage  $U_o$  is plotted against the force  $F$  for the F30. Note that the strictly linear range is covered by 30 cN (30 g). The accuracy specified in the technical data applies to this range. On the F10 the values are correspondingly smaller.

When applying larger forces the characteristic becomes non-linear. Forces up to about 80 cN (F30) or 20 cN (F10) can be evaluated; however, no information on accuracy can be provided since the measuring systems of the individual transducers differ slightly in this respect.

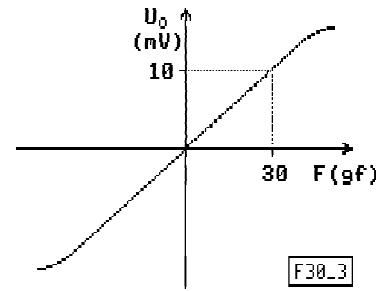

**Fig. 4:** Output voltage  $U_o$  plotted against force acting on the F30 (supply  $U_E = 1\text{ V}$ )

### 3 Notes on mounting in position

The F30 and the F10 are secured by the central threaded boss, either with the knurled nut or by directly screwing it into position.

Thread: M16 x 1 mm; length; 8 mm

Mounting bore:  $16^{+0.2}$  mm

Plate thickness: 5 mm max.

A mounting adapter with rod is supplied for mounting the transducer on a laboratory stand.

Mounting position: unrestricted

Note the following points during positioning:

- place the transducer so that no liquid can pass into it, in particular no Tyrode solution or vapour;
- when measuring extremely small forces, place the transducer in a vibration-free position or ensure that any vibrations are kept away from it;
- in order to minimise temperature drift, ensure that the transducer is not exposed directly to heat sources (lamps, heaters, direct sunlight etc.);
- do not overload the force pin on the transducer.

#### Details of the exploded view:

- (1) F30 or F10 force transducer
- (2) sensing hook cap, screwed on (T16151)
- (3) push-on hook, mounted on (2) (Z28001)
- (4) mounting adapter, side view (T18050)
- (4a) mounting adapter, seen from above (T18050)
- (5) rod for mounting on laboratory stand (T15009)
- (6) knurled nut (T16155)

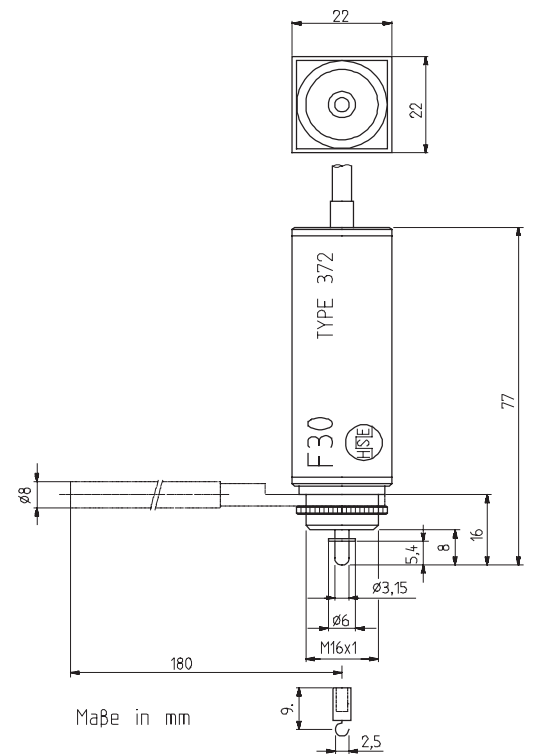

**Fig. 5:** Mounting dimensions of F30 and support rod

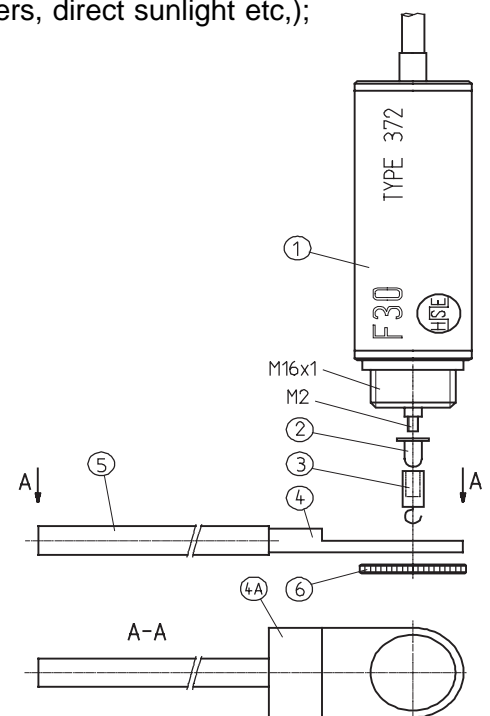

**Fig. 6:** Exploded diagram.  
For explanation see text

#### 4 Overload and overload protection

The force is applied to the transducers F30 and F10 as a tensile load through the pushed-on and clamped hook which slips on overload. When a tensile force is applied directly to the transducer (this is not recommended) or when a pressure is applied to the measuring pin it is important to ensure that the measuring system is not overloaded. The transducers incorporate reliable protection up to 10x full scale. Large forces, in particular in a radial direction, may damage the measuring system and result in a permanent zero error.

Compared with transducers using unsupported wires the F30 and F10 are exceptionally rugged. The reason is that the actual measuring system operates without mechanical contact and that there are no small fragile components. Massive stops protect against damage during normal use.

#### 5 Electrical connection

Operation of the F30 or F10 requires a bridge amplifier with a stabilised bridge supply within the range 0 - 10 Volt. The magnitude of the supply voltage determines the sensitivity of the transducer. It is advisable to set the supply voltage to 5 Volt. This value results in a low temperature drift with a sensitivity adequate for most applications (see Technical Data).

The transducer is normally supplied with a 6-pin Binder plug (male). Other connectors can be fitted to special order. It is essential that the connections for supply and signal output are made correctly, otherwise the transducer will not operate properly (in particular an increased temperature drift has to be expected).

Connector: Binder, 6-pin, male, Type: 09-0321-00-06

The pin connections and the colour coding of the wiring can be found in the Test and Calibration Sheet enclosed with each transducer.

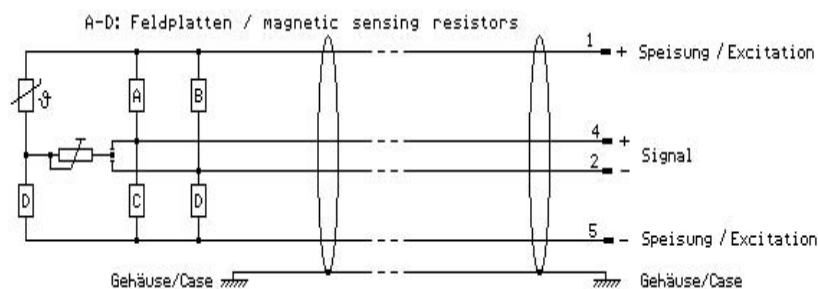

**Fig. 7:** Complete circuit of F30/F10

## 6 Calibration

The transducers F30 and F10 are supplied as standard with a calibration weight, a hook weight of 1 cN = 1 g approx. It is advisable to obtain a set of Newton calibration weights as hook weights (see below, available from HSE) in order to permit accurate calibration of intermediate values.

A standard measuring set-up consists of an F30 or F10, bridge amplifier and recorder. After connecting them together the complete system has to be calibrated in order to evaluate the amplitudes of the recorded curve. This is done by attaching a suitable calibration weight.

In order to achieve maximum accuracy the calibration weight should be of the same order as the expected force amplitudes. When using an F30 or F10 for measuring contraction forces of isolated tissues the 1 cN calibration weight as supplied is suitable. When measuring larger or smaller forces it is preferable to use suitable calibration weights from a weight set (see below).

The method described above it of course applicable only if the transducer is mounted vertically. With horizontal mounting the transducer must be calibrated with a suitably sensitive spring balance or a low-friction pulley has to be used. Another possibility is to rotate the complete apparatus so that the transducer is positioned vertically.

In certain laboratories another method is used for regular daily calibration. A calibration step is produced by placing the transducer first into the horizontal position and then turning it vertically. The weight of the moving sensor component itself then acts as a calibration weight. The weight of the moving system does however vary from one transducer to another. For this reason the deflection of each transducer must first be determined by comparison with an accurate calibration weight, and then noted. Only then can the method described be employed. With the hook placed into position, the calibration step produced is of the order of 1.5 cN.

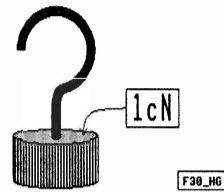
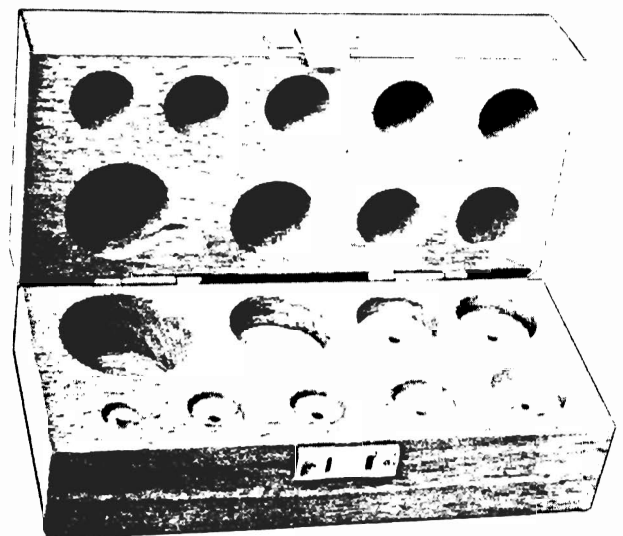
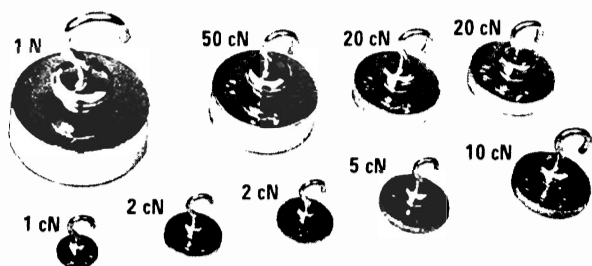

**Fig. 8:** Calibration weight supplied (1cN = 10mN = 1 g approx.)

## NEWTON Calibrating Weights

Set of polished brass precision weights with hooks, in a solid wood stand. The weights are calibrated in Newtons at the standard acceleration of gravity  $g_n = 9.80665 \text{ m/s}^2$ .

The 9 weights are: 0.01, 0.02, 0.02, 0.05, 0.1, 0.2, 0.2, 0.5, 1.0 N, corresponding to the following values in gram-force: 1, 2, 2, 5, 10, 20, 20, 50, 100, and are suitable for calibrating force transducers.



**Fig. 9:** Set of hook weights for calibrating force transducers

**7 Reduction lever (Microscale) UL5**

For the measurement of small forces there is an additional accessory for the F30, the Microscale reduction lever UL5. This attachment is screwed on to the male thread M16x1, metric fine thread, 16 mm ext. dia., 1 mm pitch) on the head of the F30.

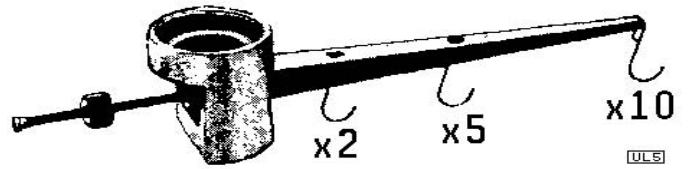
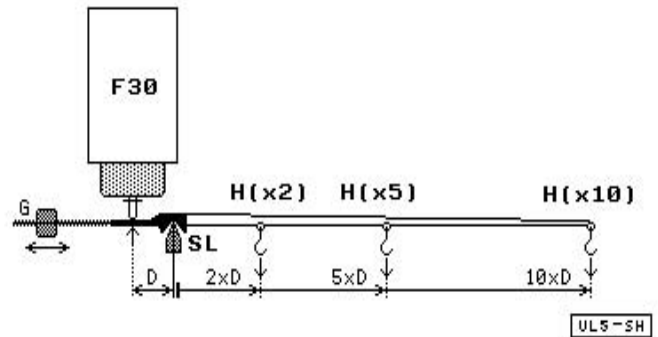

**Fig. 10:** Reduction lever UL5 for increased sensitivity

In theory it might be possible to use the reduction lever also in conjunction with the F10. There is however an increased danger of overloading combined with large hysteresis effects, so that its use is not recommended.

**IMPORTANT:** when the reduction lever UL5 is fitted to the F30 the transducer has to be handled with particular care to avoid overloading and damaging it!

The lever is intended for horizontal operation. After screwing it into position it must make an angle of 90° with the F30. Larger deviations lead to faulty operation (increased hysteresis!) and errors in measurement. Any necessary adjustments can be made after releasing the clamping screw of the knife bearing (SL, Fig. 11); however it is advisable first to check for other possible errors.



**Fig. 11:** Diagram of reduction lever UL5

Fig 11 shows the lever and its operation with the F30 in schematic form.

The lever is mounted on a knife bearing (SL) to ensure low friction. Forces which are applied at the hooks H(x2), H(x5) or H(x10) act as pressure forces on the sensing pin of the F30. According to the lever formula

$$L \times LA = F \times FA \quad (L = \text{load, LA} = \text{load arm, F} = \text{force, FA} = \text{force arm})$$

the force acting on the F30 is increased in accordance with the distance of the application point from the center of rotation. For example, a tension force of 1 cN acting at the hook H(x5) results in a compression force  $F_c$  of 5 cN on the F30. Expressed differently, in order to have a force of 5 cN acting on the F30 the tension force at the hook H(x5) need only be 1 cN.

The sensitivity of the complete system is therefore increased through the use of the UL5. Obviously the useful measurement range of the complete assembly (F30 plus UL5) is correspondingly reduced. The displacement is also increased according to the higher sensitivity.

Lever arm (hook)	Range (cN)	Displacement for full scale (mm/cN)
H (x10)	3	0.30/3
H (x 5)	6	0.15/6
H (x 2)	15	0.06/15

The lever can be balanced by means of the nut (counterweight G) which can be moved along the threaded rod.

## 8 Natural frequency and damping

Following a sudden displacement the transducers exhibit a damped oscillation as shown in Fig. 12. The following data can be derived from the curve:

natural frequency  $f_0 = 450$  Hz (F30), 180 Hz (F10)  
damping factor  $k = 1.05$

The curve shown applies only if the sensing pin of the transducer can oscillate freely and if no tissue is connected to it.

When using the reduction lever UL5 on the F30 the natural frequency is greatly reduced due to the increased moving mass. With a preload of 1 cN the frequency is of the order of  $f_0 = 50 - 70$  Hz.

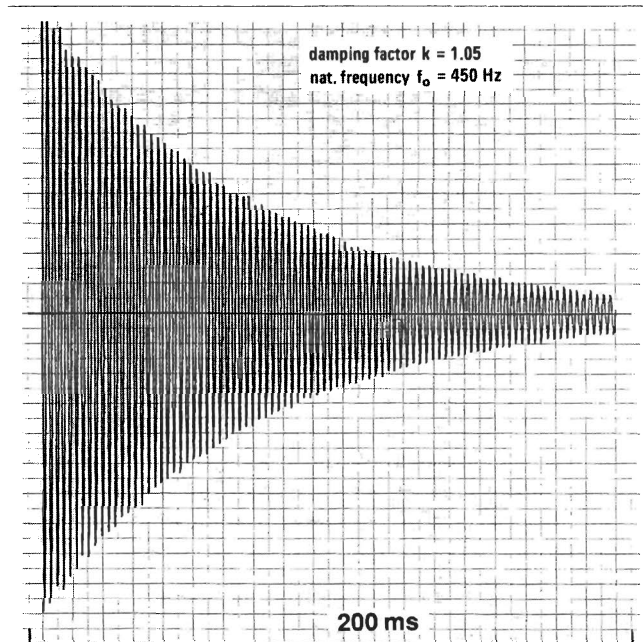

**Fig. 12:** Free oscillation of the F30 after an applied pulse

## 9 Servicing and maintenance

The transducers F30 and F10 do not require any special maintenance. Dirt on the housing is best removed with a moist cloth. With heavier dirt use a conventional laboratory cleaning agent. The cloth should not be too wet. It is essential to avoid any moisture entering the transducer. During cleaning ensure that there are no excessive forces on the sensing pin which would damage the transducer.

**Important:** the transducer must never be immersed in any liquid, for example for cleaning.

If there is any dirt in the neighbourhood of the sensing pin, try to wipe it away carefully with a small brush.

If the transducer exhibits increased hysteresis, this may be due to deposits of salt crystals close to the sensing pin between stop disk and housing. You can try to remove the dirt by means of a paper edge by sliding a folded piece of paper between the stop disk and the housing (blue).

If this cleaning operation proves unsuccessful, the transducer has to be dismantled. You should not do this yourself; if the housing is opened there is a danger that the measuring system is damaged or goes out of adjustment. Any repair is then very costly. It is better to leave this operation to experts by returning the transducer to the manufacturer for complete cleaning and overhaul.

If the transducer is not in use it is best kept in the transport case as protection against damage. Always ensure that the most sensitive element, the sensing tip, does not make any uncontrolled contact with other items; this would damage the transducer.

## 10 CE Declaration of Conformity



This product and accessories conform to the requirements of the Low-voltage Directive 73/23 EEC as well as the EMC Directive 89/336 EEC and are accordingly marked with the CE mark. For conformity to the standards during operation it is essential that the details in the instructions provided are observed.

## 11 Technical data of the F30 force transducer

	<b>F30</b>	<b>(F10)</b>
Range:	$\pm 3$ N ( $\pm 30$ cN, $\pm 30$ g)	(0.1 N)
Max. force:	$\pm 3$ N	(0.5 N)
Displacement:	$\pm 0.03$ mm ( $\pm 30$ $\mu$ m)	(60 $\mu$ m)
Isometric quotient:	1 $\mu$ m/g	(6 $\mu$ m/g)
Supply:	5 V (10 V max.)	
Sensitivity at fsd:	$\pm 10$ mV/V	(20 mV/V)
Seismic sensitivity:	1.5 cN/g (gravity)	
Natural frequency:	440 Hz	(180 Hz)
Bridge resistance:	1 kOhm full resistance bridge, can be connected to d.c. or a.c. bridge amplifiers	
Hysteresis:	<0.1%	
Linearity error:	<0.1%	
Zero drift:	<0.01 cN/K from 20 to 40°C <0.03% fsd/K / (10 mg/K)	
Drift at 10 g load:	<1% after 10 minutes	
Resolution (noise):	0.002 cN (2 mg)	(0.5 mg)
Max. load:	300%	
Failure load:	1000%	
Sensitivity to transverse forces:	<0.1%	
Max. permitted transverse force:	300%	(100 %)
Connecting cable:	1.5 m long with 6-pin Binder plug, Type 09-0321-00-06	
Weight:	200 g	
Dimensions:	22 mm x 22 mm x 70 mm	

This transducer is produced under licence from DLR (Deutsche Forschungsanstalt für Luft- und Raumfahrt e.V.) in 5000 Cologne 90, Germany

### 12 Bridge amplifiers suitable for F30

The following plug-in modules are available:

- TAM-A, transducer amplifier module Type 705/1 for PLUGSYS system
- TAM-D, transducer amplifier module Type 705/2 for PLUGSYS system
- Bridge coupler Type 570 as coupler for Mark VII recorder
- DBA, DC-bridge amplifier module Type 660 for PLUGSYS system
- CFBA, carrier frequency bridge amplifier Type 677 for PLUGSYS system
- BPA, bio-potential amplifier Type 675 for PLUGSYS system

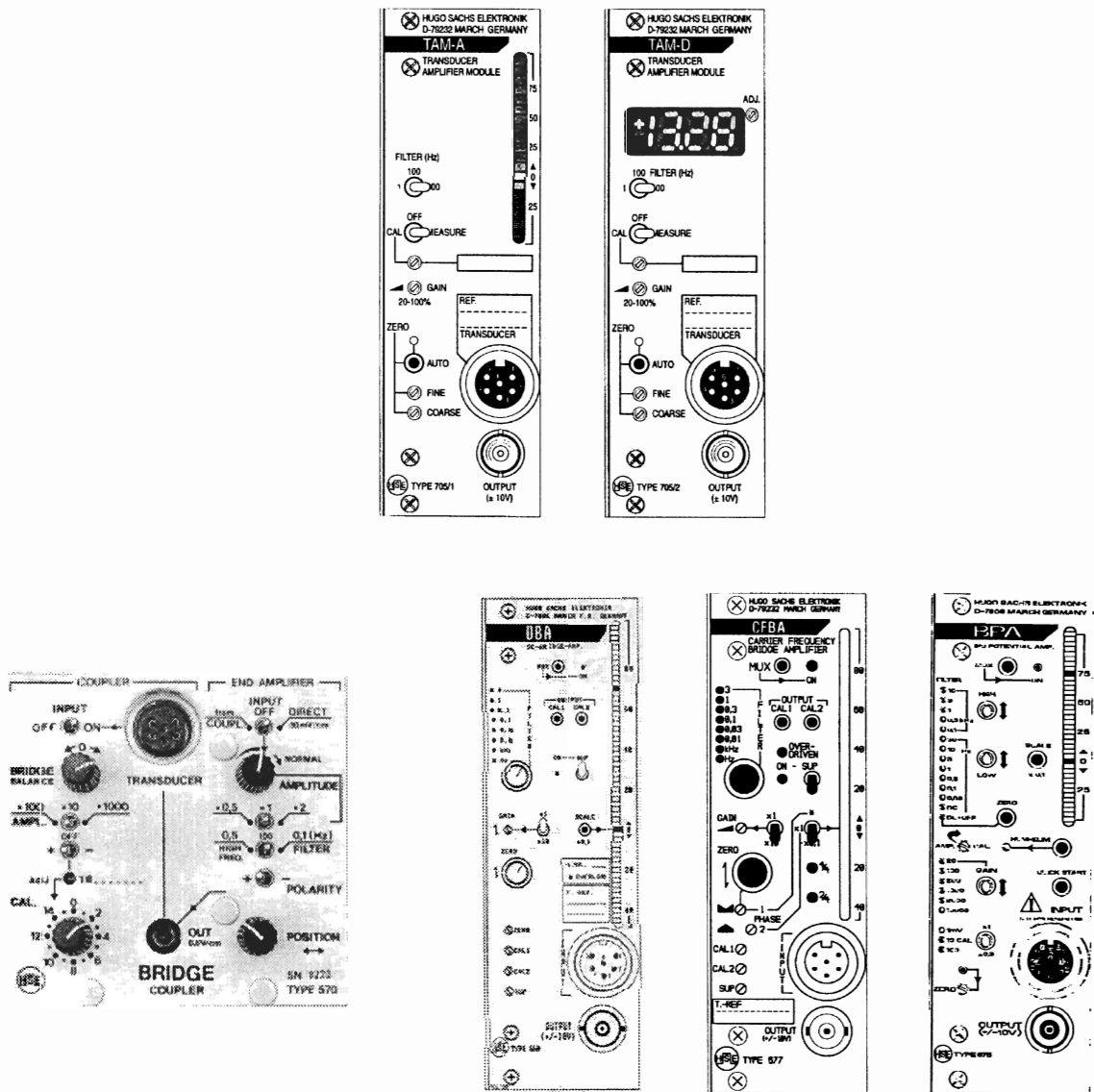

Fig. 14: The various bridge amplifiers of the HSE programme to which the F30 force transducer can be connected