



OPERATING INSTRUCTIONS

for the
Ventilators
MiniVent, Microvent, MidiVent
Type 845, 848, 849

Version: 1.6 / printed: November 2012



NOT FOR HUMAN USE



**HUGO SACHS ELEKTRONIK-
HARVARD APPARATUS GmbH**

D-79232 March-Hugstetten · Germany · Gruenstrasse 1
Tel. (+49) (0)7665 / 9200-0 · Fax (+49) (0)7665 / 9200-90
E-Mail: info@hugo-sachs.de · Internet: www.hugo-sachs.de

Contents

1.	Introduction, manufacturer's details	3
1.1	Copyright	3
2.	Safety notes	3
3.	General description, application	3
4.	Start-up	4
5.	Operating notes	4
6.	Detailed description, illustration with item numbers	5
7.	Available ventilation cannulae	6
8.	Faults and remedies	6
8.1	Faults in ventilation through mucus produced by the animal	6
8.2	Warning beep and „MOTOR OVERLOAD“ LED	6
8.3	Cleaning the plunger-cylinder system	7
8.4	What to do when the worst has happened?	8
9.	Maintenance and servicing	8
10.	Recommended cleaning agents	9
11.	Conformity	9
12.	Technical data	9
13.	Reply Form	10

Index

A

Application ... 3

B

Beep ... 5, 6, 8

C

CE symbol ... 9

Cleaning agents ... 9

cleaning the system ... 7

Condensation ... 4

Conformity ... 9

Copyright ... 3

D

Dead volume ... 4

Description detailed ... 5

dry the system ... 7

E

Earth socket ... 5

End of experiment ... 6, 8

expiration valve, washing of ... 7

F

Faults ... 6

G

General description ... 3

I

inspiration section, washing of ... 7

Introduction ... 3

Intubation cannula ... 6

Intubation cannulae ... 6

L

laboratory stand ... 4

M

Mains adapter ... 4, 5, 9

Maintenance ... 8

Manufacturer's address ... 3

Manufacturer's details ... 3

Mounting rod ... 4

MUCASOL ... 9

Mucus ... 5

N

Nutating plunger principle ... 3

O

Operating notes ... 4

R

RBS 50 / RBS 35 ... 9

Remedies ... 6

S

Safety notes ... 3

Servicing ... 8

Socket ... 4, 5

stand ... 4

Starling pump ... 3

Start-up ... 4

Stepping movement ... 6

Stroke volume ... 4, 5, 9

Supply ... 3, 4, 9

T

Technical data ... 9

Tracheal cannula ... 5, 9

Tracheal cannulae ... 6

Trachealkanülen ... 6

Tripod bar ... 4

V

Ventilation rate ... 4, 5, 9

Ventilation volume ... 3, 4, 6

W

Wash ... 6

1. Introduction, manufacturer's details

These Operating Instructions describe the function and use of the mouse ventilator Type 845. They form part of the MiniVent and have to be kept close to it.



All the information in these Instructions has been drawn up after careful examination but does not represent a warranty of product properties. Alterations in line with technical progress are reserved.

Manufacturer's address:

HUGO SACHS ELEKTRONIK-
HARVARD APPARATUS GmbH
Gruenstrasse 1,
79232 March-Hugstetten
Germany

Phone: 07665/9200-0
(int +49) 7665/9200-0

Fax: 07665/9200-90
(int +49) 7665-9200-90

Email: sales@hugo-sachs.de

Internet: www.hugo-sachs.de
www.harvardapparatus.com

1.1 Copyright

This product and the corresponding documentation are protected by copyright. All rights reserved. This document must not be copied, photocopied, reproduced or translated, either as a whole or in parts, without prior written agreement by HUGO SACHS ELEKTRONIK - HARVARD APPARATUS GmbH, March/Hugstetten, Germany.

2. Safety notes

Warning:



- The MiniVent and the mains adapter supplied with it are designed for use in general laboratories, light industrial and office environments.
- The ventilator must only be operated in areas not exposed to explosion hazard and must not be used in a flammable atmosphere.
- MiniVent and mains adapter have to be protected against humidity. The units are not suitable for outdoor use.

3. General description, application

The MiniVent mouse ventilator is a respirating pump for mouse ventilation. It operates at constant volume on the principle of the Starling pump. Unlike conventional Starling pumps the MiniVent works on the so-called nutating plunger principle in which the plunger movement determines the ventilation volume and in addition functions as the control valve. During each ventilating cycle the plunger simultaneously makes a displacement and a rotation. Suitably arranged bores and channels in plunger and cylinder operate inspiration and expiration through the plunger movement. The power supply for the pump is provided by a separate mains adapter (12 V DC, 0.5 A) which is supplied with it.

The ventilation pump is intended for use in a laboratory environment in physiological and/or pharmacological research.

4. Start-up

The illustration on the next page shows the MiniVent and the items supplied for cannulating a mouse lung. Place the MiniVent as close as possible to the animal (use laboratory stand mounting if required!) so that the tubing connections are short and the dead volume is kept small.

- For operating the MiniVent use only the mains adapter supplied (12 V DC, 0.5 A).
- Check that the input voltage marked on the mains adapter agrees with your supply voltage.
- Then connect the output cable of the mains adapter to the supply input of the MiniVent by fully pushing in the coaxial plug of the mains adapter cable into the socket at the side of the MiniVent housing. Now insert the mains adapter into a mains supply outlet socket. The green „POWER SUPPLY“ LED fitted on the MiniVent should now light up and indicate that the supply voltage is on.
- Set the ventilation rate at the control STROKES/MIN to e.g. 150 strokes/min and the ventilation volume at STROKE VOLUME (after releasing the clamping screw) to e.g. 200 µl.
- Switch on the MiniVent at the main switch and observe the pump plunger in the transparent pump cylinder. The plunger should move backwards and forwards by a few millimetres (approx. 10 mm). In addition you should be able to hear the noise of the driving motor.
- Where possible use the items supplied to connect the MiniVent to the lung of the animal:
 - 2 pieces Silicone tubing (1.5 mm i.d., approx 70 mm long)
 - 1 Y-piece (S16152)
 - 1 metal tracheal cannula, 1.3 mm dia.; other cannulae also available, see Section 7.

If the tracheal cannula supplied can not be used in your particular application, an alternative cannula should be kept as short as possible. Extend only the two connection tubes if necessary. Always keep the connection from the Y-piece to the animal as short as possible.

- If you can not place the MiniVent on the bench, use the clamping block to mount the unit on the rod of a laboratory stand (up to 12.7 mm diameter). Note: the clamping block can be rotated through 90° after releasing the two fixing screws.

5 Operating notes

During ventilation, the moist expired air cools, leading to condensation in the expiration circuit (expiration tube 1g and connectors 1e and 1d). This is normal and does not interfere with the pumping action.

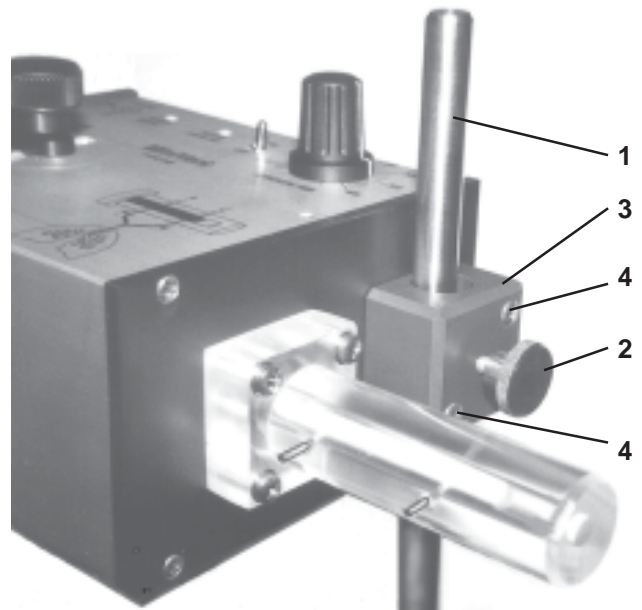

MiniVent, fastened at a laboratory stand.
1: Tripod bar, 2: clamping screw, 3: clamping block,
after releasing two screws (4) the block can be rotated
through 90°.

6. Detailed description, illustration with item numbers

The item numbers in the following description refer to the illustration below.

- 1 Pump cylinder with connectors (1b - 1e), hard glass with Plexiglass casing
 - 1a Nutating linear plunger, glass ceramic.
 - 1b Connector for drawing in air or ventilation gas.
 - 1c Connector for inspiration tube (1f).
 - 1d Outlet connector for expiration air. If a defined raised PEEP (positive end expiratory pressure) is required, the connector can be connected to a so-called Gottlieb valve (= a tube immersed in water; immersion depth determines PEEP).
 - 1e Connector for expiration tube (1g).
 - 1f Inspiration tube (Silicone tubing, 1.5 mm i.d., 3 mm o.d., L 70 mm approx.
 - 1g Expiration tube (Silicone tubing, 1.5 mm i.d., 3 mm o.d., L 70 mm approx.
 - 1h Y-piece (HSE No. S 16152) for connecting the two tubes (1f + 1g) to the tracheal cannula (1i).
 - 1i Ventilation cannula, thin-walled metal tube. It is inserted directly (without intermediate tubing) into the bore of the Y-piece (see Section 7).
- 2 Rotary control for adjusting the ventilation rate „80 - 400 STROKES/MIN“.
 - 3 Main switch „ON - OFF“ for the drive motor.
 - 4 Red „MOTOR OVERLOAD“ LED. The LED flashes when the motor is overloaded. A warning beep is produced at the same time. The motor is only overloaded if there is a fault, e.g. if mucus has found its way into the plunger-cylinder region. Remedy: wash out (see Section 7).
 - 5 Green „POWER SUPPLY“ LED. This LED indicates that the supply (12 V) is on.
 - 6 Socket to DIN 45323, suitable for hollow plug (d = 1.95 mm, D = 5.5 mm) to connect the MiniVent to the external mains adapter (12 V DC, 0.5 A). The socket is fitted in the side of the housing.
 - 7 Earth socket (suitable for 4 mm banana plug). When simultaneously recording an ECG, for example, it may be useful to earth the housing at this socket in order to prevent hum interference.
 - 8 Rotary control to adjust the STROKE VOLUME, 30 - 300 (μ l). After releasing the clamp (rotate knurled head approx. 1/2 turn anticlockwise) the required volume can be set. Then secure the volume setting (tighten knurled head clockwise).
 - 9 Clamping block to mount the MiniVent on a laboratory stand support rod up to 12.7 mm diameter. After releasing two screws the block can be rotated through 90° to fit it in an alternative position.
 - 9a Clamping screw.

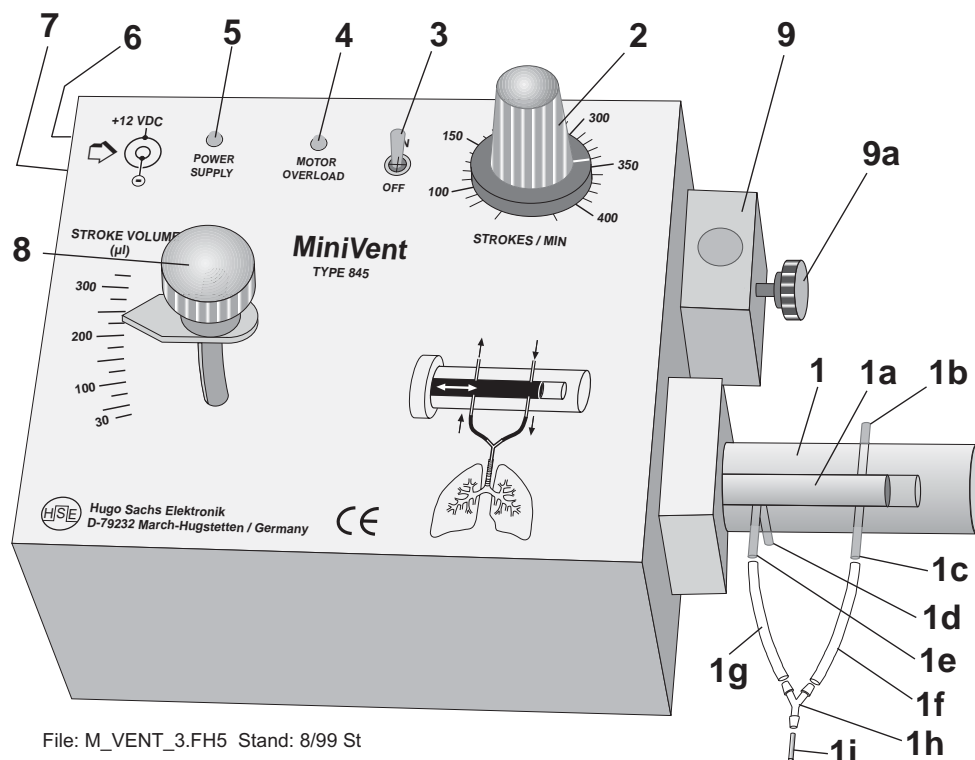

File: M_VENT_3.FH5 Stand: 8/99 St

7. Available ventilation cannulae

Tracheal cannulae with y-adapter

Cat. No.	D (mm)	d (mm)	L (mm)
73-2730 *)	1.3	1.0	20
73-2830	1.2	0.9	20
73-2731	1.0	0.7	20

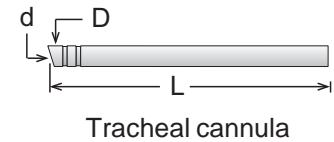

Intubation cannulae with y-adapter

73-2737	1.0	0.6	25
73-2843	1.1	0.7	30
73-2844 *)	1.2	0.8	30

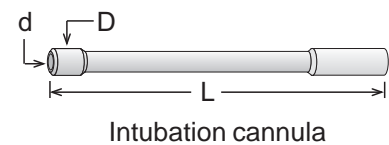

*) : this size cannula is supplied together with the ventilator.

D: external diameter, d: internal diameter, L: length

8. Faults and remedies

8.1 Faults in ventilation through mucus produced by the animal

During ventilation, especially during prolonged experiments, it is possible for mucus produced by the animal to pass through the expiration tube into the plunger expiration valve. This mucus causes no problem expect for possible disturbance of the expiration process (increased PEEP).

After the experiment has been completed you should always check the plunger-cylinder system to see whether any mucus has passed into it. If you notice any mucus, wash the expiration section thoroughly with distilled water while the MiniVent is running. If there are large amounts of mucus you should use 10% acetic acid solution. During the wash vary the ventilation volume over the entire adjustment range.

Never allow any mucus to dry out!

The plunger may stick to the cylinder wall so that it can not be released later or only with a great amount of effort (see Section 7.4).

8.2 Warning beep and „MOTOR OVERLOAD“ LED

When the drive motor is overloaded the built-in protection system causes the motor to switch off briefly and then on again. With this stepping movement the motor tries to overcome the blockage. The red „MOTOR OVERLOAD“ LED flashes at the same time and a beep indicates faulty operation.

Under normal conditions the motor is overloaded only when the plunger-cylinder system has become dirty (see above). This fault can be rectified by washing the system (see below).

8.3 Cleaning the plunger-cylinder system

Usually it is only the valve tract of the expiration section and the corresponding tubing which have become dirty. It is only rarely that the pump section of the inspiration tract also becomes dirty and sticks.

WARNING: use only the recommended cleaning agents (see Section 10).

For cleaning the expiration valve use a syringe with distilled water (see top illustration alongside).

NOTE: use only gentle pressure on the plunger, do not use any force! There is a possibility that liquid can be forced into the inside of the ventilator which may lead to corrosion damage.

Take off the expiration tubing and clean it separately from the pump, or replace it by fresh tubing.

If the inspiration section has become dirty, you can use the pumping action of this part for cleaning. Connect up two short lengths of tubing as shown in the bottom illustration alongside. If there is heavy contamination and the use of distilled water is not sufficient to clean the ventilator, you should wash it with cleaning solution (see Section 10).

During the washing operation switch on the ventilator. Select a slow rate of about 100/min and set initially the minimum stroke volume (30 μ l). Once the plunger again moves freely inside the cylinder, increase the volume up to the maximum (300 μ l). As a final step always wash all passages with clean distilled water.

After all the dirt has been washed out of the system, you have to dry the system before you can use the ventilator again. The simplest method is to link the inspiration outlet connection to the expiration connection with a piece of tubing at least 40 cm long, and run the pump at maximum ventilation rate (400/min) and maximum stroke volume. After about 30 minutes the system should be dry.

WARNING: do not use compressed air for drying the system!

If the ventilator is blown through with compressed air, the uncontrolled high air pressure may drive moisture into the inside of the pump which can damage the drive mechanism.

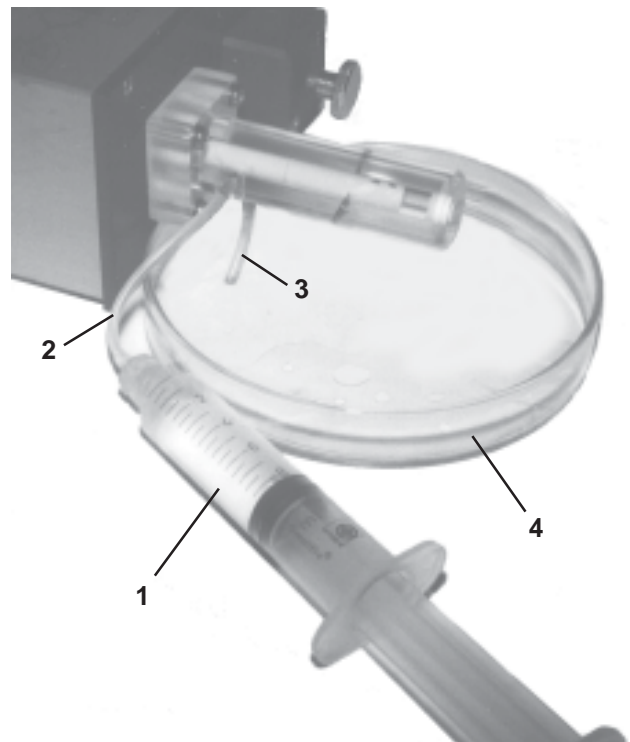

Washing the expiration valve
1: syringe, 2 and 3: short lengths of tubing,
4: Petri dish for collecting the wash liquid

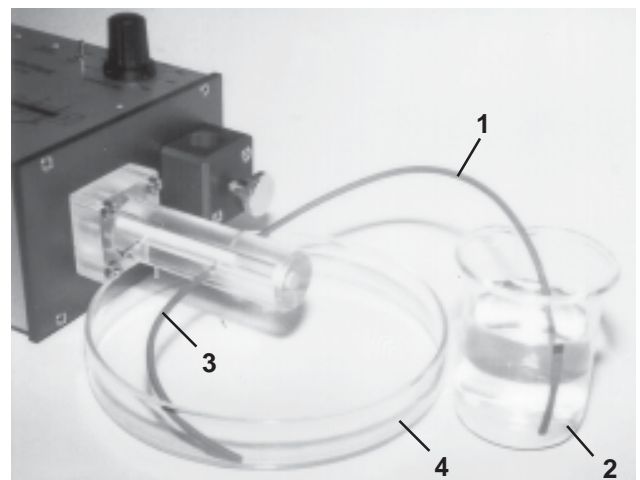

Washing the inspiration section
1: suction tubing, 2: small beaker with distilled water, 3:
outlet tubing, 4: Petri dish for collecting the wash liquid

8.4 What to do when the worst has happened?

You note that the plunger no longer moves inside the cylinder when you switch on the ventilator. Instead there is a repeated beep and the red „MOTOR OVERLOAD“ LED is flashing. In this case it must be assumed that the last user of the ventilator has not cleaned it properly to remove any mucus at the end of the experiment. In the meantime the mucus has dried out so that plunger and cylinder stick together.

What do you do in this case?

WARNING: on no account try to resolve the problem by the use of force!

When the plunger is stuck you must not alter the stroke volume setting. You would risk damaging the plunger drive mechanism.

There are two way to restore the pump to working order:

- (a) you return the MiniVent immediately to HSE for repair, or
- (b) you try to restore proper operation of the plunger.

The method for restoring the movement of the plunger consists of filling the plunger-cylinder system through the connections to the maximum possible extent with cleaning solution (see Section 10), and to allow it to stand in this condition for a few hours, in the hope that during this time the dried mucus starts to dissolve and becomes liquid again. Link together the two connections on the inspiration side by a short piece of tubing, and the two connections on the expiration side by another short piece of tubing; this ensures that the solution will not dry out.

Switch on the pump from time to time for a few seconds and check whether the treatment is effective. When you find that the plunger moves a little, remove the front tubing (inspiration section) and at first carefully adjust the stroke volume in small steps over the entire adjustment range. Then remove also the other connecting tubing (expiration section) and clean the complete pump system as explained in Section 8.3. After you have dried the pump system the pump can be used again.

9. Maintenance and servicing

The most important maintenance operation consists of keeping the plunger-cylinder system clean. After each experiment you should check immediately that no mucus has entered the pump system. If you note any contamination you should clean the pump system immediately. Do not wait until the mucus has dried out and the plunger is sticking to the cylinder.

The drive mechanism for the plunger inside the unit is lubricated for life. No special maintenance is required.

The plunger-cylinder system must not be lubricated. This would not improve the running of the pump but would rather make it worse. The combination of plunger and cylinder material is designed for dry running.

It is obvious that any external contamination through blood or saline solutions must be removed immediately. Use a cloth moistened with water. If removal proves difficult, add a little detergent.

During all cleaning procedures take care that no liquid can pass into the interior. Do not use a wet cloth for cleaning, only a moist cloth!

10. Recommended cleaning agents

Use only the recommended cleaning agents!

IMPORTANT: not all cleaning agents used in the laboratory are suitable for cleaning Plexiglass parts. For example, MucocitF manufactured by Merz (Frankfurt) attacks Plexiglass.

NOTE: the cylinder casing is made from Plexiglass.

In order to avoid damage to the plunger-cylinder system you must use only the recommended cleaning agents. Never use organic solvents, they usually attack Plexiglass.

If for certain reasons you require a different cleaning agent you have to carry out a compatibility test before using it. In case of doubt contact HSE.

Cleaning agent for washing mucus residues out of the plunger-cylinder system:

10% acetic acid solution

WARNING: allow the acetic acid to act only for a few minutes!

In order to avoid damage to the ventilator you must allow the 10% acetic acid to act only briefly. More concentrated acetic acid solution must never be used!

Other cleaning solutions compatible with Plexiglas:

RBS 50 or RBS 35

produced and

supplied by:

Carl Roth GmbH + Co KG, Chemische Fabrik,
Schoemperlenstr. 1-5, D-76185 Karlsruhe 21, Germany
Phone: (+49) (0)721/5606-0, Fax: (+49) (0)721/5606-49,
e-mail: Carl@t-online.de, Internet: <http://www.Carl-Roth.de>

MUCASOL

produced by:

Merz + Co. GmbH & Co. Bereich Dr.Kramer,
Eckenheimer Landstrasse 100-104, D-60318 Frankfurt/Main 1, Germany
Phone: 069/15031, Telex: 414 031

Supplier:

Firma Rudolf BRAND GmbH & Co. P. O. Box 11 55, D-97861 Wertheim, Germany
Phone :(+49) (0)9342/808-0, Fax: (+49) (0)9342/808-236

USA,

Supplier:

Brand Tech. Scientific, 25 Middlesex Turnpike, Essex, CT 06426-1479
Phone 860-767 2562

If there is any difficulty in contacting a local distributor for the above products please contact the apparatus manufacturer HUGO SACHS ELEKTRONIK - HARVARD APPARATUS GmbH.

11. Conformity



This product and accessories conform to the requirements of the Low-Voltage Guideline 73/23/EWG as well as the EMC Directive 89/336/EWG and are accordingly marked with the CE symbol. For conformity with the standard it is essential that the details in these Instructions are strictly observed during operation.



12. Technical data

Stroke volume:	continuously adjustable from 30 to 350 µl
Ventilation rate:	continuously adjustable from 80 to 400 min ⁻¹
Supply:	12 V DC, 0.5 A through external mains adapter
Dimensions (LxWxH):	20 cm x 10 cm x 8 cm
Weight:	MiniVent: 1 kg, mains adapter: 0.3 kg

13. Reply Form

Please take a few minutes of your time in order to write to us on any difficulties in understanding the Operating Instructions or in the use of the apparatus. With your feedback you will help to improve our products and the system documentation and make them more user-friendly.

Please tell us

-  where you have found mistakes,
-  where the arrangement was not clear and what you did not understand,
-  and where you would like to see improvements.

Many thanks for your *kind assistance*.
Yours HUGO SACHS ELEKTRONIK-
HARVARD APPARATUS GmbH.

Your name _____
Organisation _____
Street _____
Town _____
Phone / Fax _____
eMail _____

Please send this sheet or a copy to:

HUGO SACHS ELEKTRONIK - HARVARD APPARATUS GmbH
Gruenstr. 1, D-79232 March-Hugstetten, Germany
Fax: (int. +49) 7665/9200-90

Conversion Table for PRESSURE units

mmHg (Torr)	kPa (kN/m ²)	mmH ₂ O (mmWS)	mbar	at (kg/cm ²)	PSI (lb/in ²)
1	0,133	13,6	1,33	0,0014	0,019
2	0,267	27,2	2,67	0,0027	0,039
3	0,400	40,8	4,00	0,0041	0,058
4	0,533	54,4	5,33	0,0054	0,077
5	0,667	68,0	6,67	0,0068	0,097
6	0,800	81,6	8,00	0,0082	0,116
7	0,933	95,2	9,33	0,0095	0,135
8	1,067	108,8	10,67	0,0109	0,155
9	1,200	122,4	12,00	0,0122	0,174
10	1,333	136,0	13,33	0,0136	0,193
20	2,666	271,9	26,66	0,0272	0,387
30	4,000	407,9	40,00	0,0408	0,580
40	5,333	543,8	53,33	0,0544	0,773
50	6,666	679,8	66,66	0,0680	0,967
60	7,999	815,7	79,99	0,0816	1,160
70	9,333	951,7	93,32	0,0952	1,354
80	10,666	1087,6	106,66	0,1088	1,547
90	11,999	1223,6	119,99	0,1224	1,740
100	13,332	1359,5	133,32	0,1360	1,934
120	15,999	1631,4	159,98	0,1631	2,320
140	18,665	1903,3	186,65	0,1903	2,707
160	21,332	2175,2	213,31	0,2175	3,094
180	23,998	2447,1	239,98	0,2447	3,481
200	26,664	2719,0	266,64	0,2719	3,867
250	33,331	3398,8	333,30	0,3399	4,834
300	39,997	4078,5	399,96	0,4079	5,801

mmH ₂ O (mmWS)	cmH ₂ O (cmWS)	mmHg	Pa (N/m ²)	kPa (kN/m ²)	PSI (lb/in ²)
1	0,1	0,07	9,8	0,0098	0,0014
2	0,2	0,15	19,6	0,0196	0,0028
3	0,3	0,22	29,4	0,0294	0,0043
4	0,4	0,29	39,2	0,0392	0,0057
5	0,5	0,37	49,0	0,0490	0,0071
6	0,6	0,44	58,8	0,0588	0,0085
7	0,7	0,51	68,6	0,0686	0,0100
8	0,8	0,59	78,5	0,0785	0,0114
9	0,9	0,66	88,3	0,0883	0,0128
10	1	0,74	98,1	0,0981	0,0142
20	2	1,47	196,1	0,1961	0,0284
30	3	2,21	294,2	0,2942	0,0427
40	4	2,94	392,3	0,3923	0,0569
50	5	3,68	490,3	0,4903	0,0711
60	6	4,41	588,4	0,5884	0,0853
70	7	5,15	686,5	0,6865	0,0996
80	8	5,88	784,5	0,7845	0,1138
90	9	6,62	882,6	0,8826	0,1280
100	10	7,36	980,7	0,9807	0,1422
120	12	8,83	1176,8	1,1768	0,1707
140	14	10,30	1372,9	1,3729	0,1991
160	16	11,77	1569,1	1,5691	0,2276
180	18	13,24	1765,2	1,7652	0,2560
200	20	14,71	1961,3	1,9613	0,2845
220	22	16,18	2157,5	2,1575	0,3129
240	24	17,65	2353,6	2,3536	0,3414
260	26	19,13	2549,7	2,5497	0,3698
280	28	20,60	2745,8	2,7458	0,3982
300	30	22,07	2942,0	2,9420	0,4267

OUR PRODUCTS

- Pumps
- Delivery and Sampling
- Animal Handling and Containment
- Surgical Equipment
- Surgical Instruments
- Respiration
- Respiratory Mechanics
- Behavioral Equipment
- Transducers, Stimulators, Amplifiers, and Recorders
- Cardiovascular Isolated Organ and Tissue Educational Programs
- Neuroscience
- Cell Biology
- Molecular Biology
- Toxicology
- General Lab
- CPK™ Atomic Models

Call the office nearest you for more information or service requests



A Harvard Apparatus, Inc. Company



USA

Harvard Apparatus, Inc.
84 October Hill Road
Holliston, Ma. 01746
Phone: 508-893-8999
Toll Free: 800-272-2775
Fax: 508-429-5732
E-mail: bioscience@harvardapparatus.com

FRANCE

Harvard Apparatus, S.A.R.L.
6 Avenue des Andes
Miniparc - Bat. 8
91952 Les Ulis Cedex
Phone: (33) 1 64 46 00 85
Fax: (33) 1 64 46 94 38
E-mail: harvard@isp.fr

HUGO SACHS ELEKTRONIK - HARVARD APPARATUS GmbH
D-79232 March-Hugstetten
Gruenstrasse 1
Phone: (49) 7665 9200 0
Fax: (49) 7665 9200 90
E-mail: sales@hugo-sachs.de
Internet: www.hugo-sachs.de

CANADA

Harvard Apparatus, Canada
6010 Vanden Abeele St.
Saint Laurent, Quebec H4S 1R9
Phone: 514-335-0792
Toll Free: 800-361-1905
Fax: 514-335-3482
E-mail: harvardcanada@compuserve.com

U.K.

Harvard Apparatus, Ltd.
Fircroft Way, Edenbridge
Kent TN8 6HE
Phone: (44) 1732 864-001
Fax: (44) 1732 863-356
E-mail: harvard@twins.co.uk

Internet: www.harvardapparatus.com



**HUGO SACHS ELEKTRONIK-
HARVARD APPARATUS GmbH**
Gruenstrasse 1
D-79232 March-Hugstetten / Germany

Phone: 07665 / 92 00-0
Fax: 07665 / 92 00-90
E-mail: sales@hugo-sachs.de
Internet: www.hugo-sachs.de

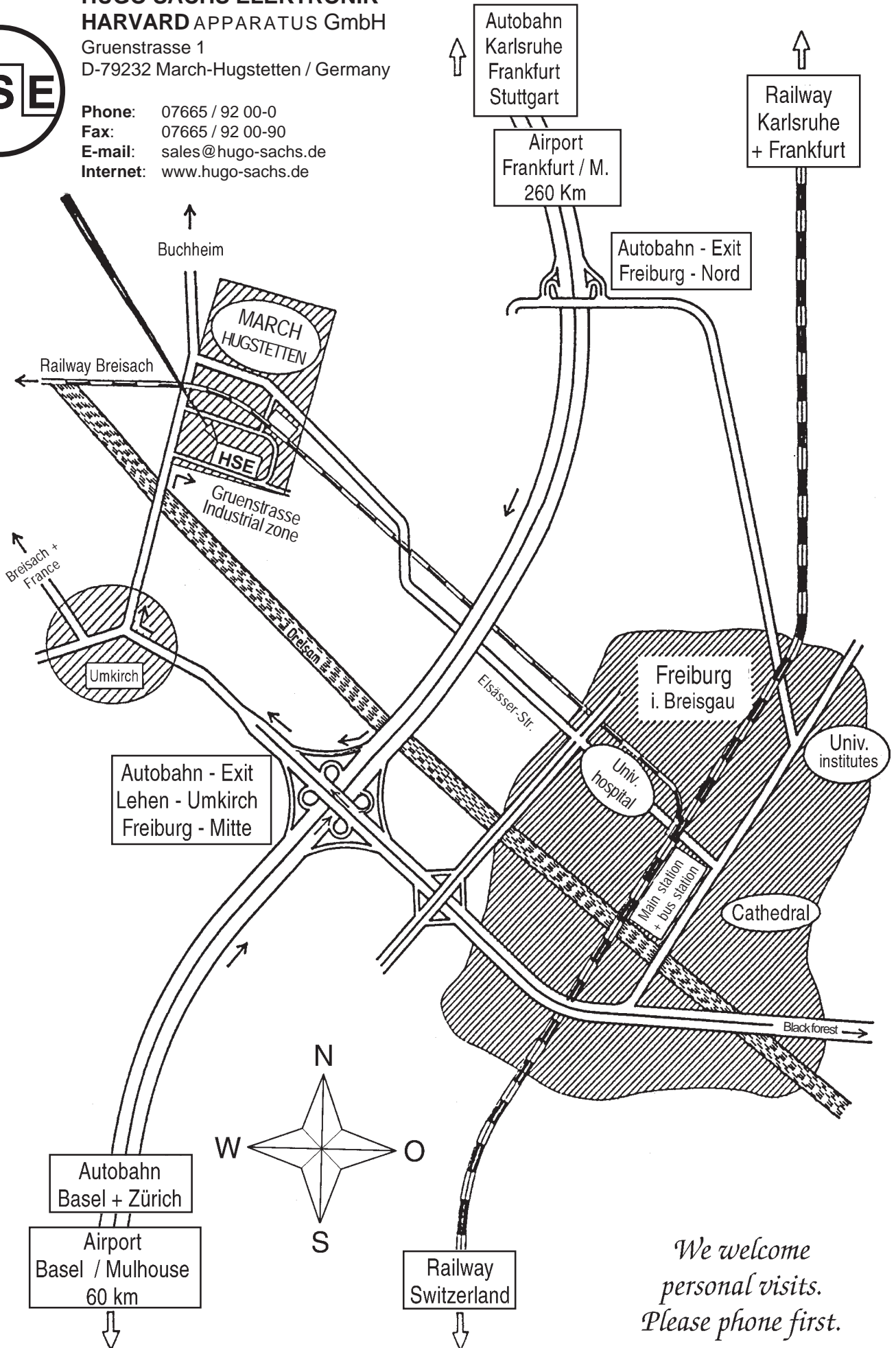

*We welcome
personal visits.
Please phone first.*